

ROUND METAL CEILING LOUDSPEAKERS

- **RCS4FT/EN**
- **RCS4FT/ENC**

EN54-24



TECHNICAL SPECIFICATIONS

EN54-24:2008

Certificate No: 0359-CPD-0120 TYPE A

ELECTRICAL

Rated power, Watts	4
Tappings 100 volt line, Watts	4/2/1/0.5/0.25
Transformer Impedance, Ohms 100V	2.5k/5k/10k/20k/40k
Tappings 70.7 volt line, Watts	2/1/0.5/0.25/0.13
Driver impedance, Ohms	8
Effective Frequency Range, Hz (BSEN60268-5)	200 - 18K
S.P.L. @ 4m, 1watt, dB, 1/3 Octave, 1kHz	60
S.P.L. @ 1m, 1watt, dB, Test Signal Bandwidth 100Hz-10kHz	83
S.P.L. @ 4m, Full power, dB, 1/3 Octave 1kHz	66
S.P.L. @ 1m, Full power, Test Signal Bandwidth 100Hz-10kHz	89
Dispersion at 1k/2kHz, Degrees	180/180

ENVIRONMENTAL

IP-Rating	21
Max/Min Amb Temp	55°/-10°C
Relative Humidity	≤95%

MECHANICAL

Dimensions, mm	Height 101, Ø132
Net Weight, Kgs	0.92
Colour (Unless Specified)	RAL9016
Material	Steel
Mounting	Fixing Springs x 4 (stainless steel)
Cut-out, mm	Ø119

- RCS4FT/ENC is supplied with capacitor for DC line monitoring

RCS4FT/EN RCS4FT/ENC

ROUND METAL CEILING LOUDSPEAKERS

EN54-24

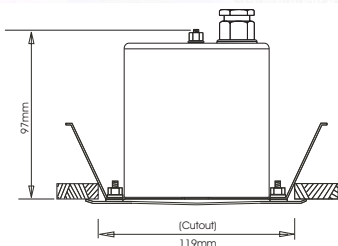
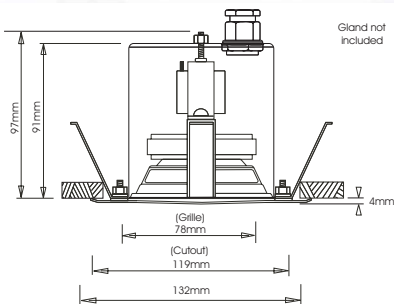

RCS4FT/EN & RCS4FT/ENC
* Unit fitted with Capacitor

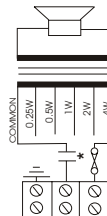

WITH TRANSFORMER: 100V/70V LINE

	WHITE WIRE PLUS TAPPING					BLACK
100V	0.25W	0.5W	1W	2W	4W	COM
70V	0.13W	0.25W	0.5W	1W	2W	COM
IMP (Ω)	40K	20K	10K	5K	2.5K	

DISPERSION ANGLES

		HORIZONTAL	VERTICAL
1 OCT. PINK NOISE	500 Hz	180°	180°
1 OCT. PINK NOISE	1K Hz	180°	180°
1 OCT. PINK NOISE	2K Hz	180°	180°
1 OCT. PINK NOISE	4K Hz	120°	120°

FREQUENCY RESPONSE

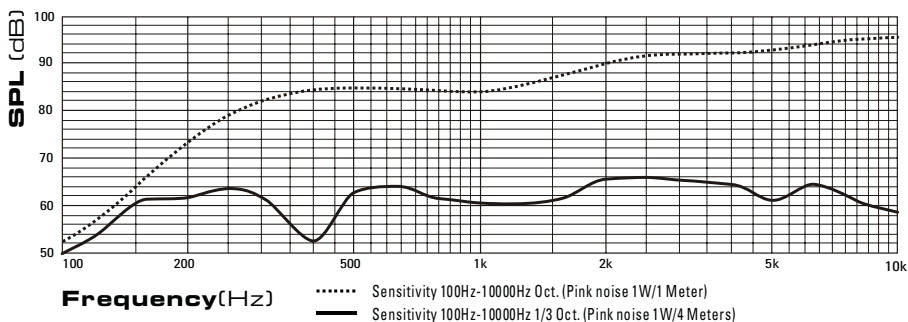

The RCS4FT/EN & ENC have been tested for 100 hours at a maximum power of 4W. Both units did not deviate by more than +/- 3dB. The frequency response and impedance curves remained constant throughout the test period. All results are in full compliance with the requirements of EN54-24.



Penton UK Ltd

Unit 2 Teville Industrials | Dominion Way | Worthing | West Sussex | BN14 8NW
 T: +44 (0)1903 215315 | F: +44(0)1903 215415 | E: SALES@PENTONUK.CO.UK

www.pentonuk.co.uk

