



## ACOUSTIC & ELECTRO-ACOUSTIC CONSULTANTS

Rayleigh House  
21 Queen Anne's Place, Bush Hill Park  
North London EN1 2QB  
Tel: 020 8360 5988 Fax: 020 8360 2640  
E-mail: [amsac@btinternet.com](mailto:amsac@btinternet.com)  
Web-site: [www.amsacoustics.co.uk](http://www.amsacoustics.co.uk)

Partners:  
P.W. Barnett MIOA, MASA, F.Inst., SCE, MAES  
J.L. Goddard (administration)  
Associates:  
H.M. Goddard MIOA, M.Inst., SCE, MAES  
P.N. Huffer B.Sc., MIOA

# Loudspeaker Test Report

Manufacturer: Penton (UK) Ltd

Type: Bi-Directional

Model: Cell 10/BDT

For: Penton (UK) Ltd

Report No.: 1191/LS/Cell 10/BDT

Prepared By: A. N. Stacey B.Sc., AMIOA

© AMS Acoustics, London

**Electro-Acoustics:**  
Sound System Design  
Conference Systems  
Reverberation Enhancement  
Emergency Evacuation System Design  
Loudspeaker & Microphone Testing

**Environmental Acoustics:**  
Noise Nuisance  
Traffic Survey  
HSE – Hearing Risk  
Expert Witness

**Speech Intelligibility:**  
Prediction Models  
RASTI Measurements  
Word Score Measurements

**Architectural & Building Services**  
Acoustics:  
Building Services Noise  
Room Acoustics  
Reverberation Control  
Noise Control

Offices in: Hong Kong and USA

VAT No 645 5591 14

## 1. Object

- 1.1. The object of this Report is to present measurements of the acoustic performance of the Cell 10/BDT device.

## 2. Scope

- 2.1. The following characteristics were measured

- On-axis frequency response
- Polar response
- Impedance
- Applied voltage
- On-axis 3<sup>rd</sup> octave band sound pressure level

from which the following are calculated

- a) Directivity Index (dB), tabulated and graphical
- b) Directivity factor, Q
- c) Effective octave band impedance
- d) Octave band Sensitivity (dB @ 1m, 1W/oct)
- e) Overall Sensitivity:
  - dBA @ 1m, 1W
  - dBlin @ 1m, 1W
  - 250Hz-4kHz @ 1m, 1W
  - Speech shape @ 1m, 1W
- f) Acoustic Power (dB-PWL @ 1W), tabulated and graphical
- g) Octave band Power Apportionment (%)
- h) Impedance bode plot
- i) Expected maximum Sound pressure level (dB @ 1m)
- j) Frequency response chart
- k) Polar response charts

### **3. Method**

- 3.1. The device was mounted in Free Space as shown in figure 1 – Mounting method E.
- 3.2. The measurements were made in an anechoic chamber.
- 3.3. Measurements were made as detailed in AMS Test Method document No. IR/1a/LS/Meth.
- 3.4. All measurements were made in general accordance with BS 6840: Part 5: 1995.

### **4. Results**

- 4.1. The On-axis 3<sup>rd</sup> octave frequency response of the device is shown graphically in the appendix.
- 4.2. The Impedance bode plot of the device is shown graphically in the appendix.
- 4.3. Polar plots of the device are shown graphically in the appendix.
- 4.4. Tabulated values of Directivity index, Directivity factor, Sensitivity, Acoustic Power, Power Apportionment, Impedance and Maximum SPL are shown in the Summary data sheet given in the appendix.
- 4.5. The Directivity Index has been calculated using Gerzon' equal angle, weighted area method.

### **5. Notes**

- 5.1. Sensitivity  
The octave band sensitivity is produced in its useful form for calculations. It should be noted that the octave band sensitivity is given as dB @ 1m, 1W/Oct. To determine the output when only the overall power is known, then only the overall dBA or dBLin values should be used. For more detailed information refer to AMS Acoustics Data Sheet 'Loudspeaker Sensitivity – Interpretation of Results'.
- 5.2. Polar Plots  
For convenience each polar plot has been normalized to 0dB. For this reason caution is advised when comparison of levels between octave bands is made. The reference axis frequency response should be used for comparison purposes.

## **6. Engineers Notes**

Reference point located at the geometric centre of the enclosure.

Reference plane located parallel to drivers and includes the reference point.

## Loudspeaker Information

Manufacturer : Penton (UK) Ltd  
Model Code : Cell 10/BDT  
Type : Bi-Directional  
Colour : White  
Serial No. : None  
Batch No. : None  
Other Markings : Penton label  
Backbox : As Supplied  
Grille : As Supplied  
Weight (grammes) : 2300  
Depth (mm) : 198 mm  
Width (mm) : 142 mm  
Height (mm) : 142 mm  
Special Features : NM

### Internal Details

Driver Types/Sizes : 2 x 120mm drivers  
Driver Serial No.(s) : NM  
Driver Markings : NM  
Damping Material : NM  
Available Tappings : 20W, 10W, 5W, 2.5W (100V)

### Electrical Details

Resonant Frequency(s) : See Impedance Plot  
Cross-Over Frequency(s) : N/A  
Nominal Impedance (ohms): 8  
Inductance : NM  
Capacitance : NM

NM = Not Measured, NA = Not Applicable

Originator:

Countersigned:



Manufacturer : Penton (UK) Ltd  
 Model Code : Cell 10/BDT  
 Mounting : Full-Space, Free Field  
 Transformer Tapping : 20W

Reference Axis Located at : 0 degrees

Parameter	Frequency (Hz)								dB	dBA
	125	250	500	1k	2k	4k	8k			
Axial Q	1.1	0.8	0.4	2.2	2.8	6.2	6.0			
Directivity Index (dB on Axis)	0.4	-1.0	-4.0	3.4	4.5	7.9	7.8			
Sensitivity (dB @ 1m, 1W/Oct)	81	89	81	87	90	92	87	88	88	
Sensitivity(dB @ 1m, 1W)250Hz-4kHz									89	89
Sensitivity(dB @ 1m, 1W)Speech Shape									86	82
Acoustic Power (dB-PWL @ 1W)	84	92	87	87	89	87	80			
Apportioned Power (%)	17	13	14	15	15	14	10			
Effective Impedance (Ohms)	393	526	451	444	463	508	616			
Expected maximum SPL (dB @ 1m)	87	93	85	92	95	96	90	101	101	

Test Signal: Pink Noise(100Hz-10kHz)

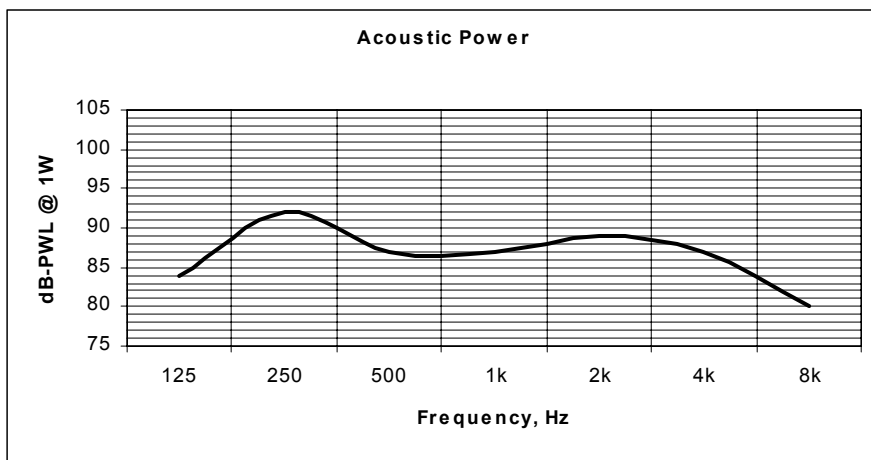
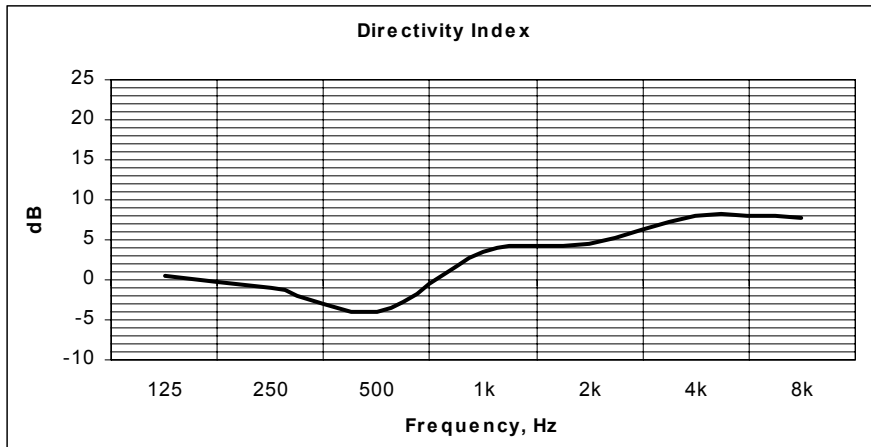

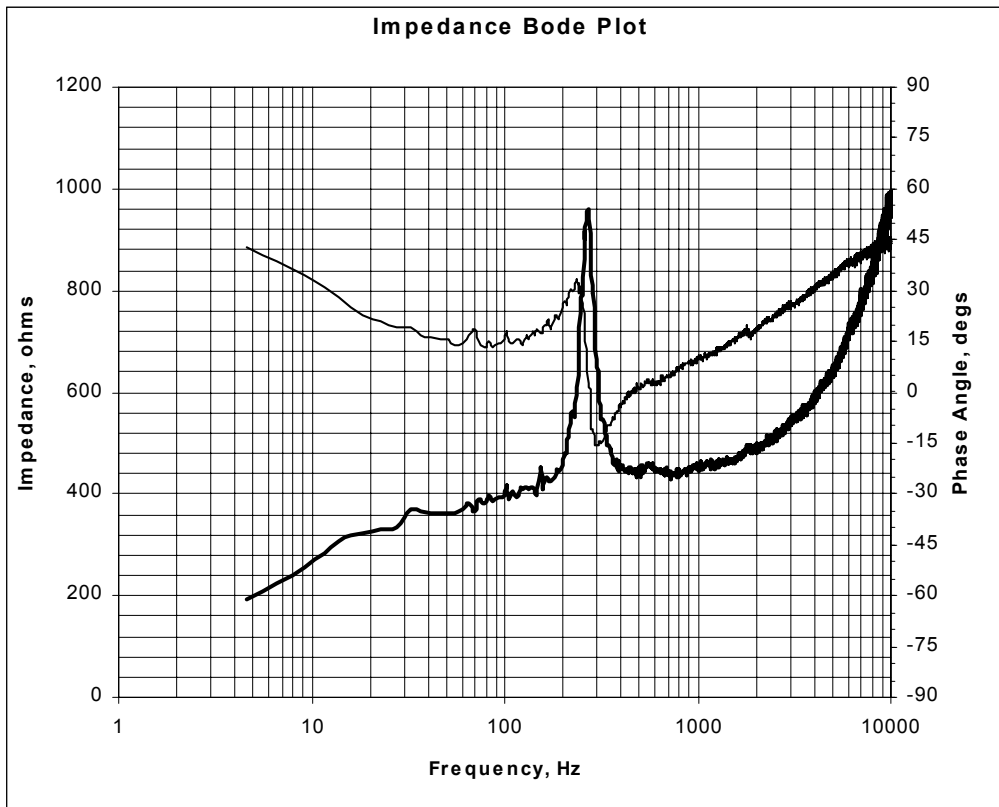
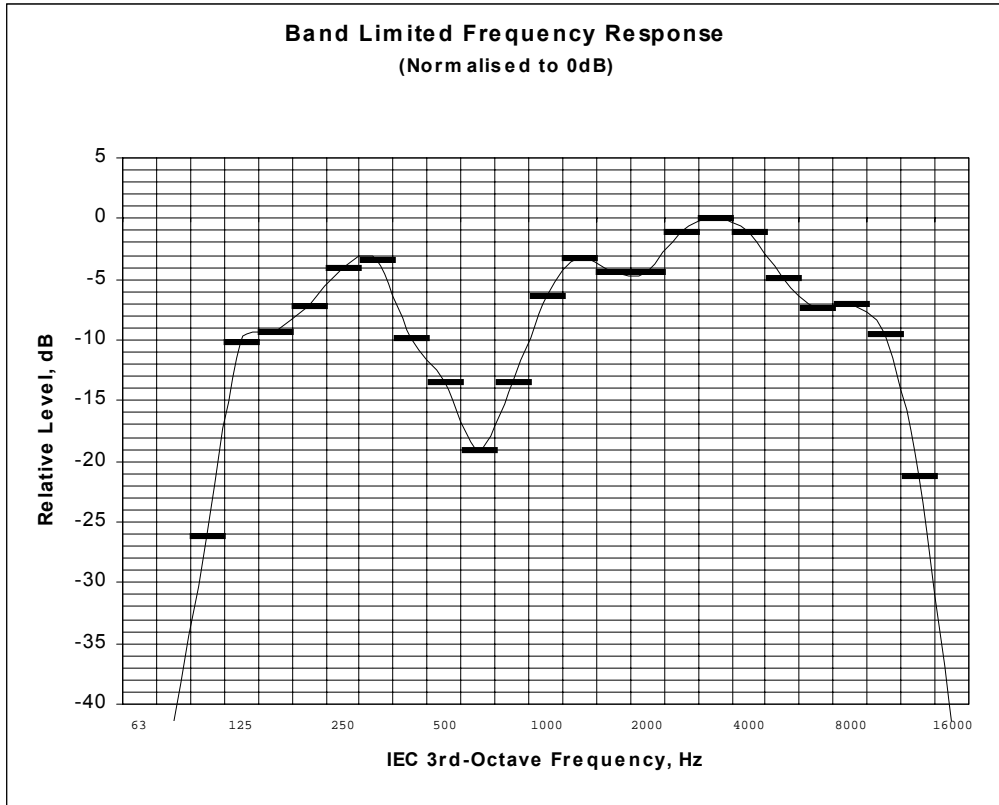

Cell 10/BDT

### Wide Band Frequency Range (Valid from 60Hz to 20kHz)

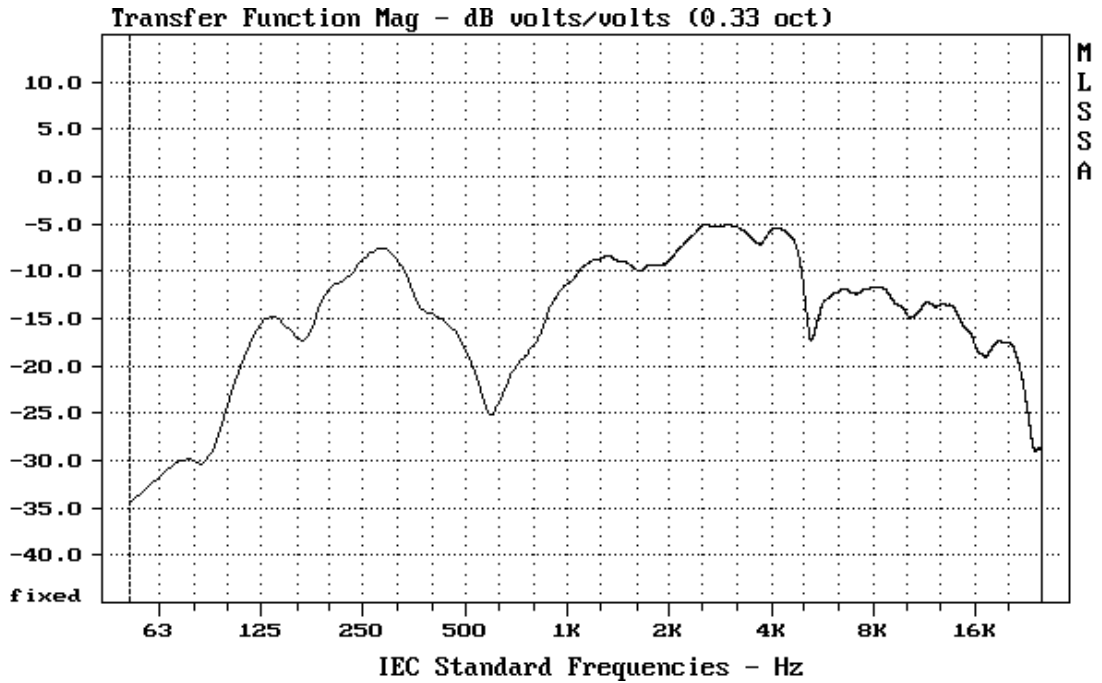

Note: The wide band frequency response is derived using MLS methods and does not relate to the sensitivity values given in the summary table.

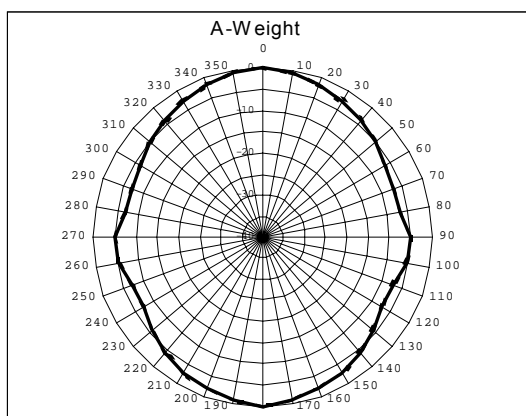
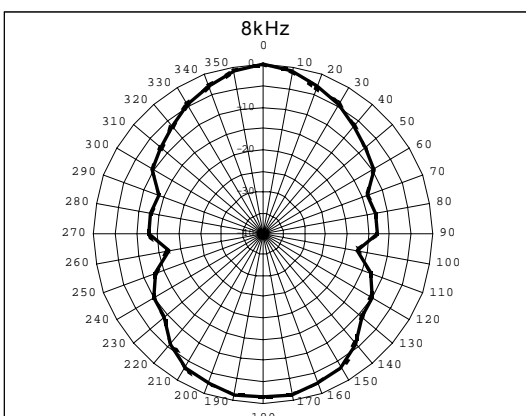
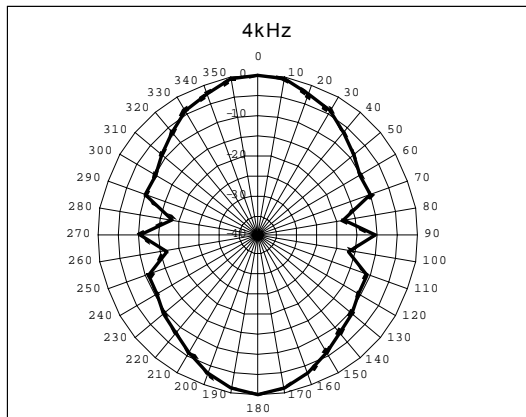
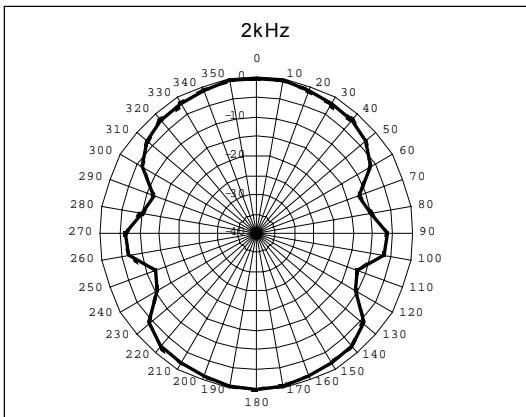
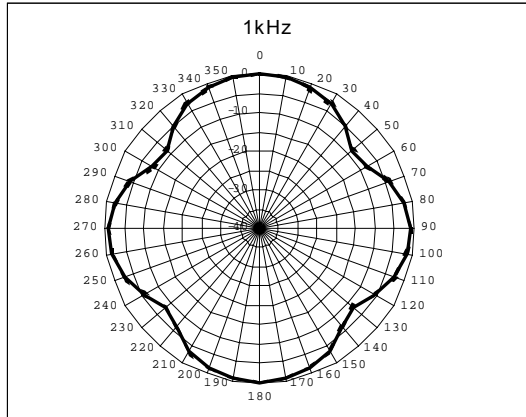
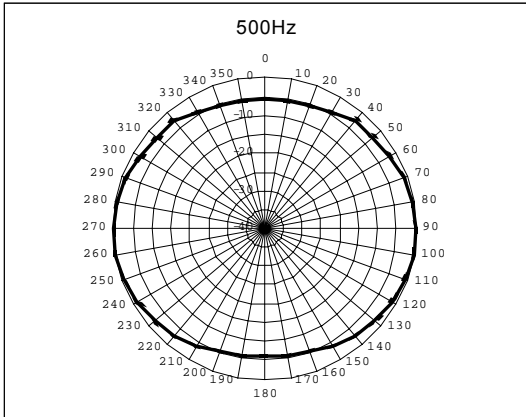
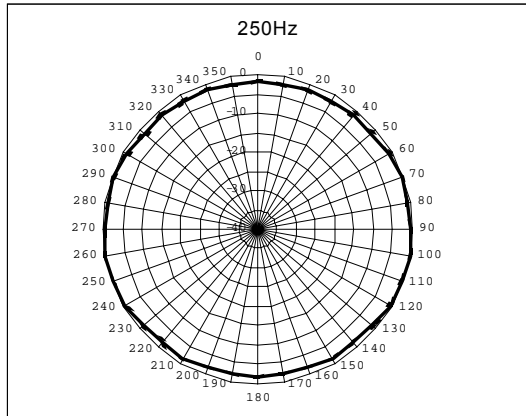
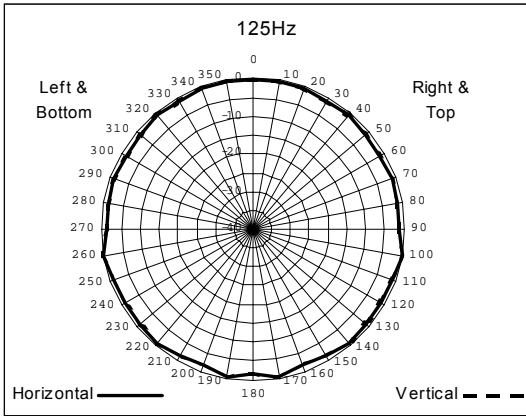

## Loudspeaker Mounting Methods

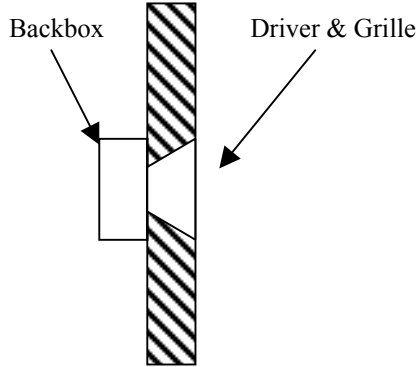

**Mounting Method A**  
Loudspeaker Mounted  
in a Reflective Baffle

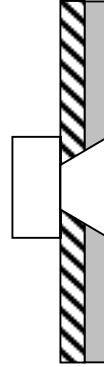

**Mounting Method B**  
Loudspeaker Mounted  
in an Absorbent Baffle

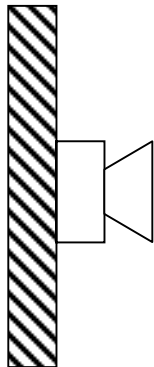

**Mounting Method C**  
Loudspeaker Mounted  
on a Reflective Baffle

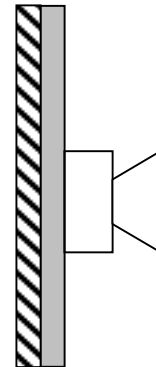

**Mounting Method B**  
Loudspeaker Mounted  
on an Absorbent Baffle

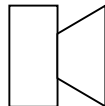

**Mounting Method E**  
Loudspeaker not Attached to any  
Surface and Radiation Unaffected by  
nearby Reflecting Surfaces