



ACOUSTIC & ELECTRO-ACOUSTIC CONSULTANTS

Rayleigh House
21 Queen Anne's Place, Bush Hill Park
North London EN1 2QB
Tel: 020 8360 5988 Fax: 020 8360 2640
E-mail: amsac@btinternet.com
Web-site: www.amsacoustics.co.uk

Partners:
P.W. Barnett MIOA, MASA, F.Inst., SCE, MAES
J.L. Goddard (administration)
Associates:
H.M. Goddard MIOA, M.Inst., SCE, MAES
P.N. Huffer B.Sc., MIOA

Loudspeaker Test Report

Manufacturer: Penton (UK) Ltd

Type: Column

Model: MCS 80/T

For: Penton (UK) Ltd

Report No.: 1191/LS/MCS 80/T

Prepared By: A. N. Stacey B.Sc., AMIOA

© AMS Acoustics, London

Electro-Acoustics:
Sound System Design
Conference Systems
Reverberation Enhancement
Emergency Evacuation System Design
Loudspeaker & Microphone Testing

Environmental Acoustics:
Noise Nuisance
Traffic Survey
HSE – Hearing Risk
Expert Witness

Speech Intelligibility:
Prediction Models
RASTI Measurements
Word Score Measurements

Architectural & Building Services
Acoustics:
Building Services Noise
Room Acoustics
Reverberation Control
Noise Control

Offices in: Hong Kong and USA

VAT No 645 5591 14

1. Object

- 1.1. The object of this Report is to present measurements of the acoustic performance of the MCS 80/T device.

2. Scope

- 2.1. The following characteristics were measured

- On-axis frequency response
- Polar response
- Impedance
- Applied voltage
- On-axis 3rd octave band sound pressure level

from which the following are calculated

- a) Directivity Index (dB), tabulated and graphical
- b) Directivity factor, Q
- c) Effective octave band impedance
- d) Octave band Sensitivity (dB @ 1m, 1W/oct)
- e) Overall Sensitivity:
 - dBA @ 1m, 1W
 - dBlin @ 1m, 1W
 - 250Hz-4kHz @ 1m, 1W
 - Speech shape @ 1m, 1W
- f) Acoustic Power (dB-PWL @ 1W), tabulated and graphical
- g) Octave band Power Apportionment (%)
- h) Impedance bode plot
- i) Expected maximum Sound pressure level (dB @ 1m)
- j) Frequency response chart
- k) Polar response charts

3. Method

- 3.1. The device was mounted in Free Space as shown in figure 1 – Mounting method E.
- 3.2. The measurements were made in an anechoic chamber.
- 3.3. Measurements were made as detailed in AMS Test Method document No. IR/1a/LS/Meth.
- 3.4. All measurements were made in general accordance with BS 6840: Part 5: 1995.

4. Results

- 4.1. The On-axis 3rd octave frequency response of the device is shown graphically in the appendix.
- 4.2. The Impedance bode plot of the device is shown graphically in the appendix.
- 4.3. Polar plots of the device are shown graphically in the appendix.
- 4.4. Tabulated values of Directivity index, Directivity factor, Sensitivity, Acoustic Power, Power Apportionment, Impedance and Maximum SPL are shown in the Summary data sheet given in the appendix.
- 4.5. The Directivity Index has been calculated using Gerzon' equal angle, weighted area method.

5. Notes

- 5.1. **Sensitivity**
The octave band sensitivity is produced in its useful form for calculations. It should be noted that the octave band sensitivity is given as dB @ 1m, 1W/Oct. To determine the output when only the overall power is known, then only the overall dBA or dBLin values should be used. For more detailed information refer to AMS Acoustics Data Sheet 'Loudspeaker Sensitivity – Interpretation of Results'.
- 5.2. **Polar Plots**
For convenience each polar plot has been normalized to 0dB. For this reason caution is advised when comparison of levels between octave bands is made. The reference axis frequency response should be used for comparison purposes.

6. Engineers Notes

Reference point located at the geometric centre of the enclosure.

Reference plane located parallel to the driver baffle and includes the reference point.

Frequency response extends above 10kHz.

Cable entry flange assumed to be top of column.

Loudspeaker Information

Manufacturer : Penton (UK) Ltd
Model Code : MCS 80/T
Type : Column
Colour : White
Serial No. : None
Batch No. : None
Other Markings : Penton label
Backbox : As Supplied
Grille : As Supplied
Weight (grammes) : 5900
Depth (mm) : 90 mm
Width (mm) : 100 mm
Height (mm) : 964 mm
Special Features : External rotary tapping selector

Internal Details

Driver Types/Sizes : 8 x 75mm cone drivers, 1x HF unit
Driver Serial No.(s) : NM
Driver Markings : NM
Damping Material : Mineral fibre
Available Tappings : 80W, 40W, 20W, 10W (100V)

Electrical Details

Resonant Frequency(s) : See Impedance Plot
Cross-Over Frequency(s) : NM
Nominal Impedance (ohms): 4
Inductance : NM
Capacitance : NM

NM = Not Measured, NA = Not Applicable

Originator:

Countersigned:



Manufacturer : Penton (UK) Ltd
 Model Code : MCS 80/T
 Mounting : Full-Space, Free Field
 Transformer Tapping : 80W

Reference Axis Located at : 0 degrees

Parameter	Frequency (Hz)							dB	dBA
	125	250	500	1k	2k	4k	8k		
Axial Q	1.1	1.9	3.0	4.2	6.8	11.1	9.9		
Directivity Index (dB on Axis)	0.4	2.8	4.8	6.2	8.3	10.5	10.0		
Sensitivity (dB @ 1m, 1W/Oct)	84	94	93	95	99	99	99	96	97
Sensitivity(dB @ 1m, 1W)250Hz-4kHz								97	97
Sensitivity(dB @ 1m, 1W)Speech Shape								93	91
Acoustic Power (dB-PWL @ 1W)	85	92	91	92	94	91	90		
Apportioned Power (%)	11	11	16	17	17	15	12		
Effective Impedance (Ohms)	193	192	128	121	130	152	164		
Expected maximum SPL (dB @ 1m)	94	103	104	106	110	110	108	115	116

Test Signal: Pink Noise(100Hz-10kHz)

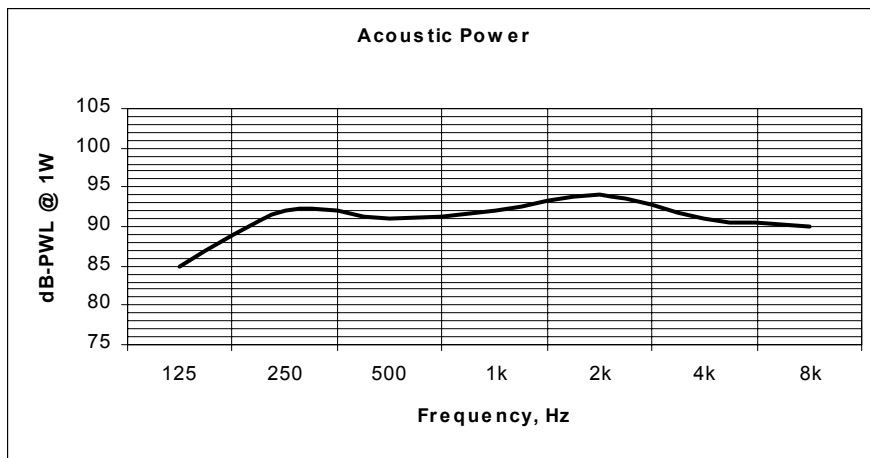
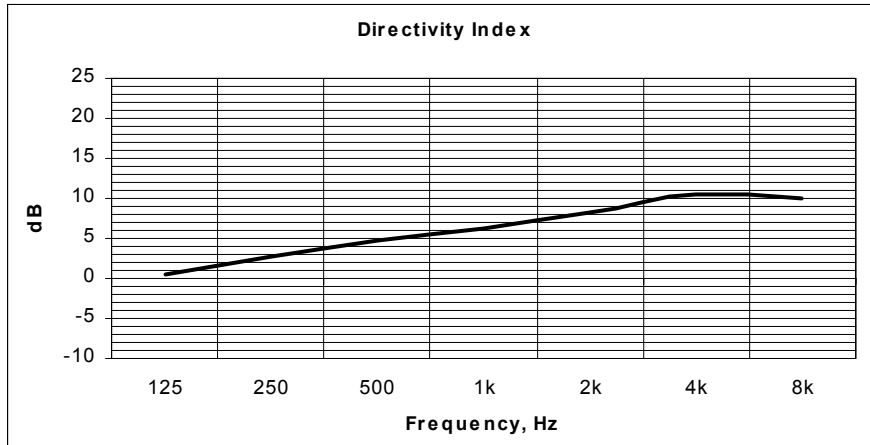

MCS 80/T

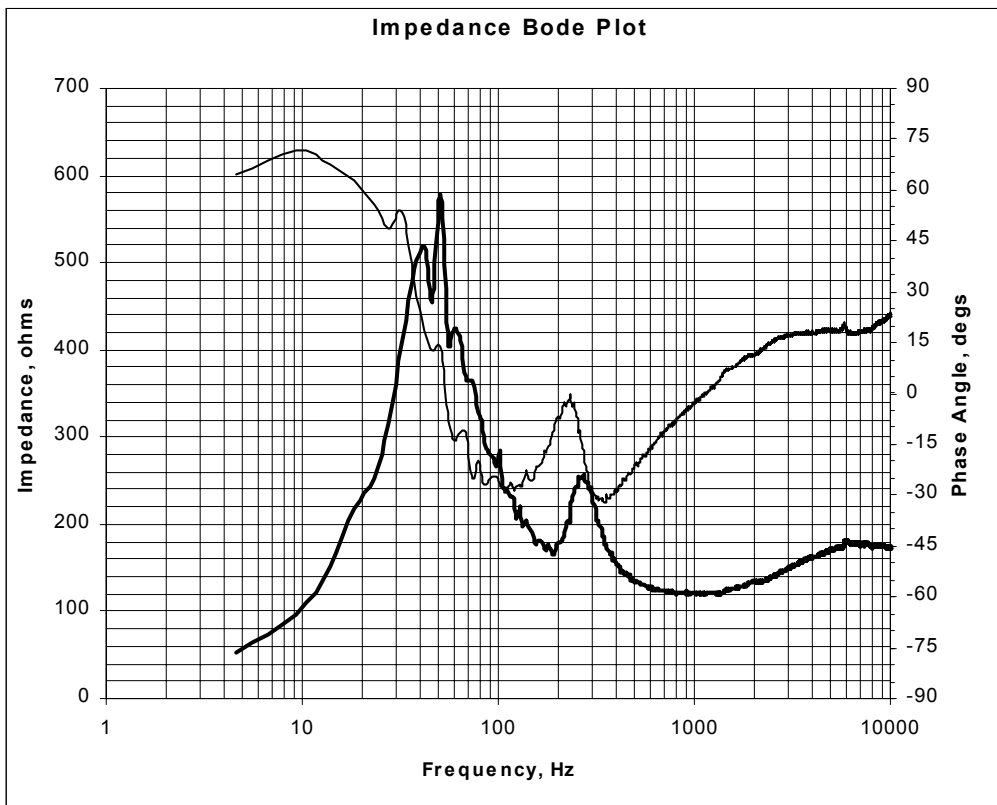
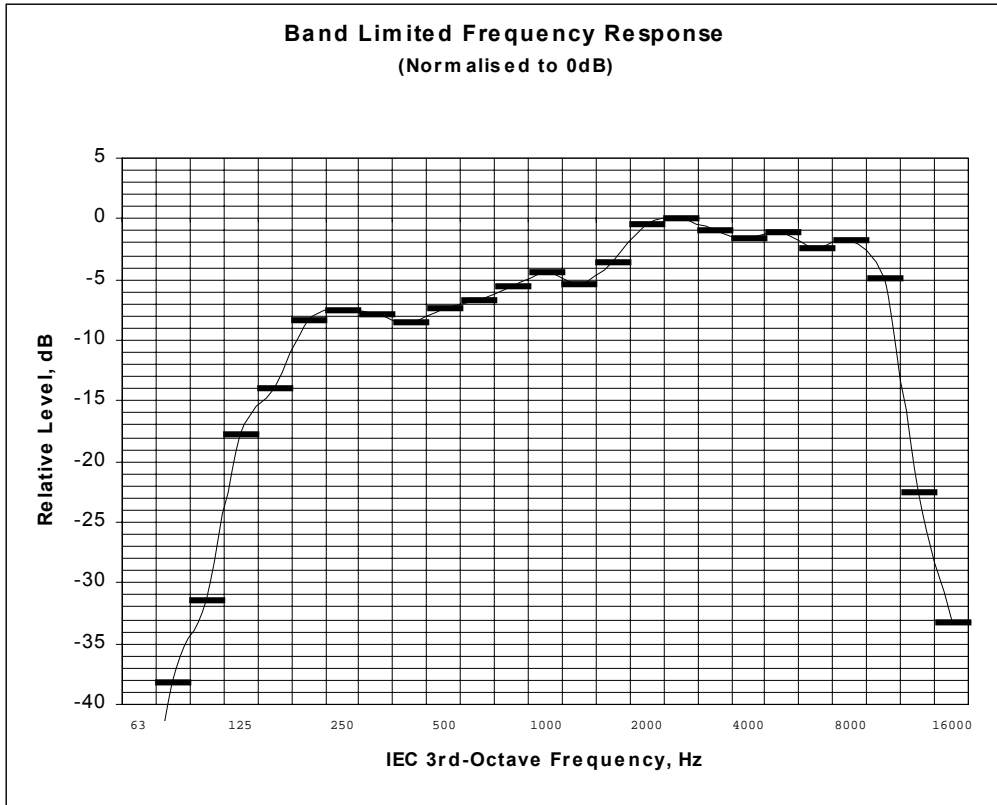

MCS 80/T

Wide Band Frequency Response (Valid from 60Hz to 20kHz)

File: A:\FREQ.FRQ 7-12-2001 11:24 AM
Transfer Function Mag - dB volts/volts (0.33 oct)

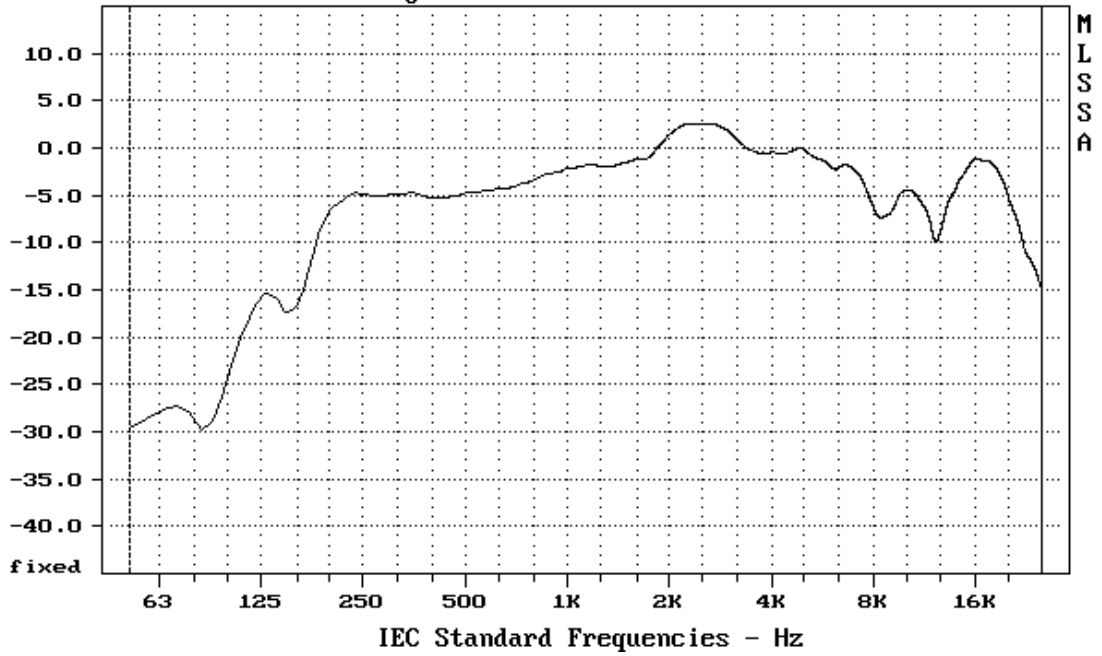

Note: The wide band frequency response is derived using MLS methods and does not relate to the sensitivity values given in the summary table.

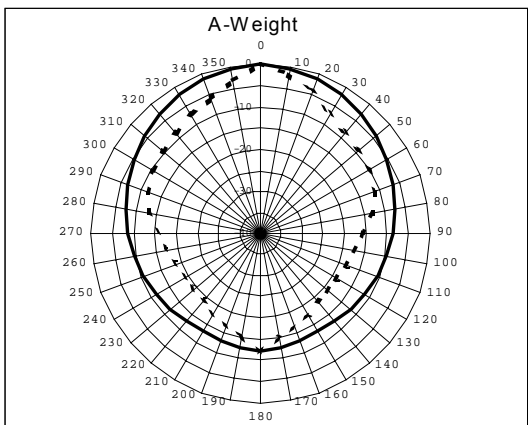
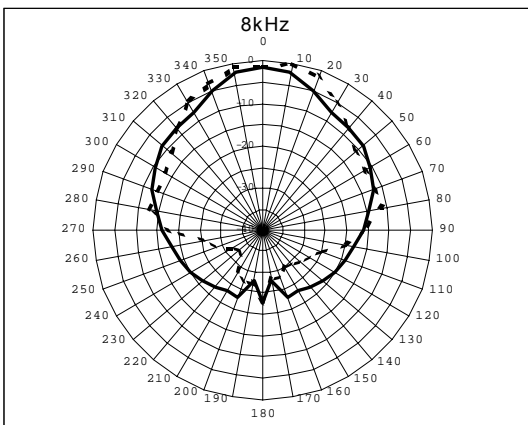
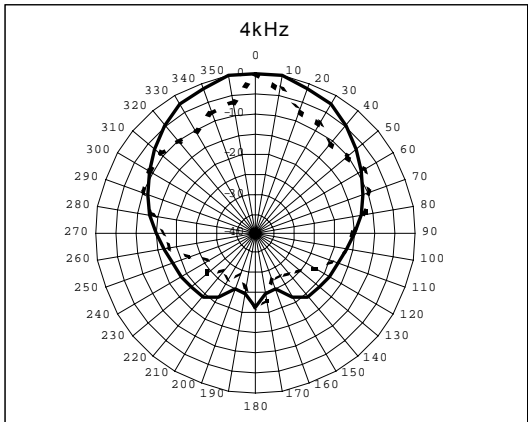
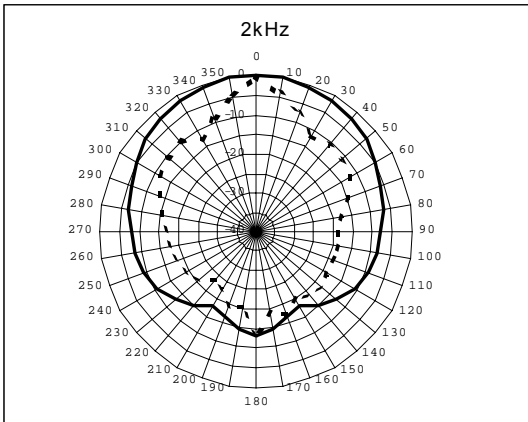
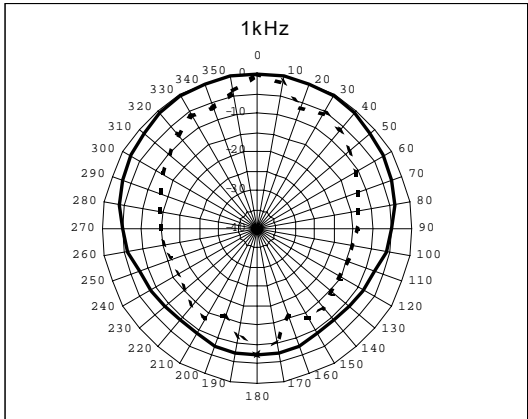
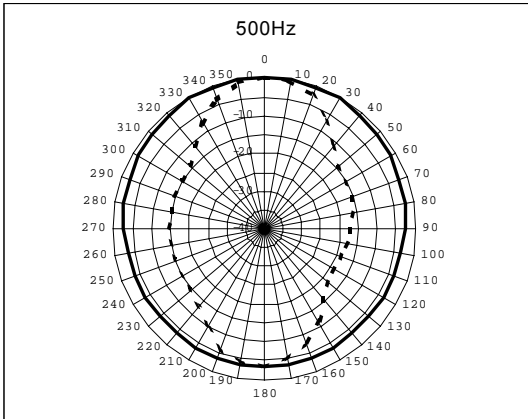
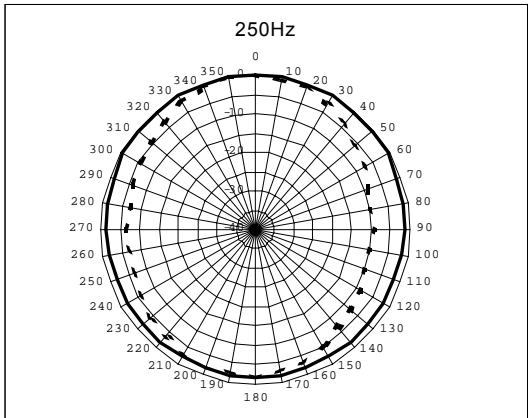
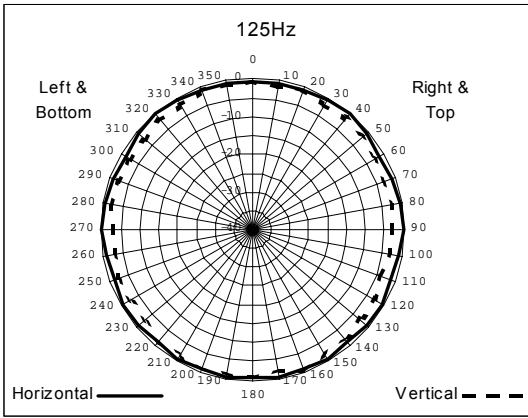

Loudspeaker Mounting Methods

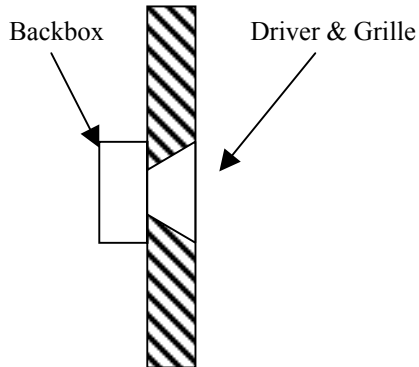

Mounting Method A
Loudspeaker Mounted
in a Reflective Baffle

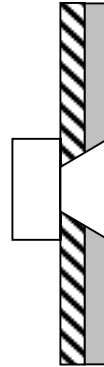

Mounting Method B
Loudspeaker Mounted
in an Absorbent Baffle

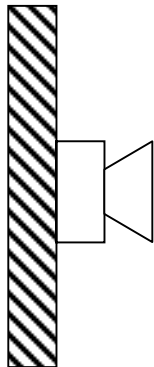

Mounting Method C
Loudspeaker Mounted
on a Reflective Baffle

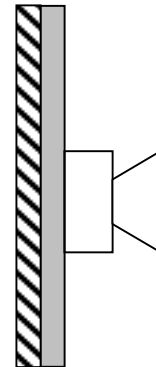

Mounting Method B
Loudspeaker Mounted
on an Absorbent Baffle

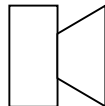

Mounting Method E
Loudspeaker not Attached to any
Surface and Radiation Unaffected by
nearby Reflecting Surfaces