

METAL SOUND PROJECTORS

- CELL 10T/EN
- CELL 10T/ENC



INSTALLATION INSTRUCTIONS

EN54-24:2008

Certificate No: 0359-CPD-0164 TYPE B

1. LOUDSPEAKER ENCLOSURE
2. REFERENCE AXIS
3. REFERENCE PLANE
4. HORIZONTAL PLANE

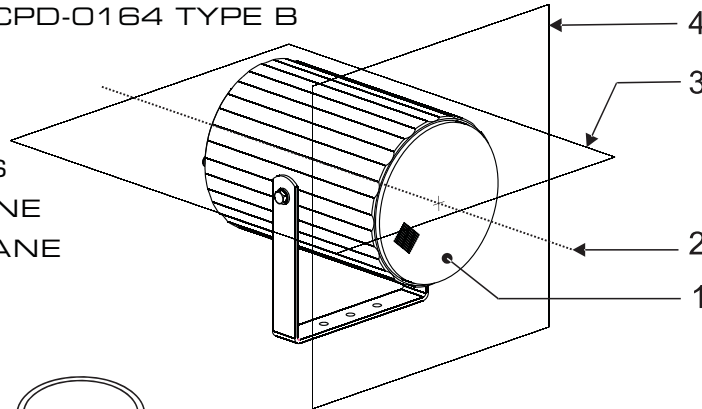

Circuit Diagram

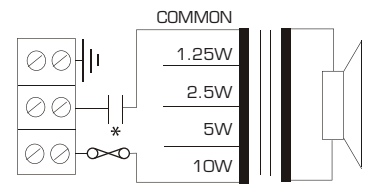

- CELL 10T/EN
- CELL 10T/ENC
- * with capacitor

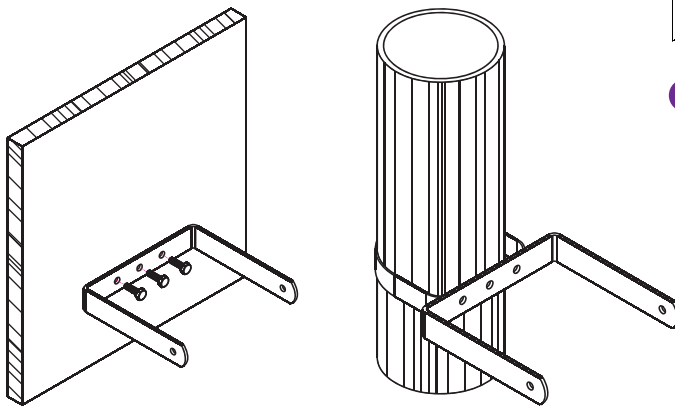

- 1. Remove the "U" bracket from the speaker. Align the bracket and mark the fixing points. Fix the bracket using suitable fixings (Not supplied).

- 2. Remove the rear cover. The installation cable can be fitted via suitably rated glands into the 1 x 20mm gland entries provided.

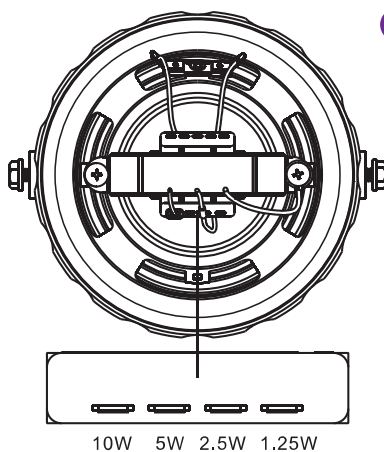
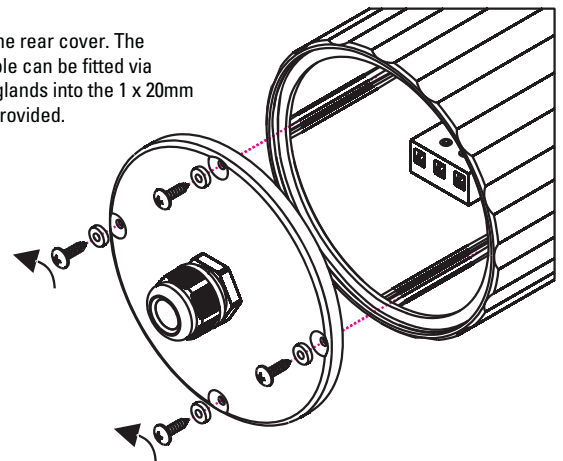

10W 5W 2.5W 1.25W

- 3. The cable can then be terminated into the terminal block fitted to the rear of the speaker. The terminals are suitable to take "loop in" "loop out" connections up to 2.5mm per core.

4. Select the desired tapping.

5. Re-fit the rear cover ensuring that the gasket is in place and that the screw fittings are fitted with their rubber washers to ensure the rear cover retains its weatherproof rating.

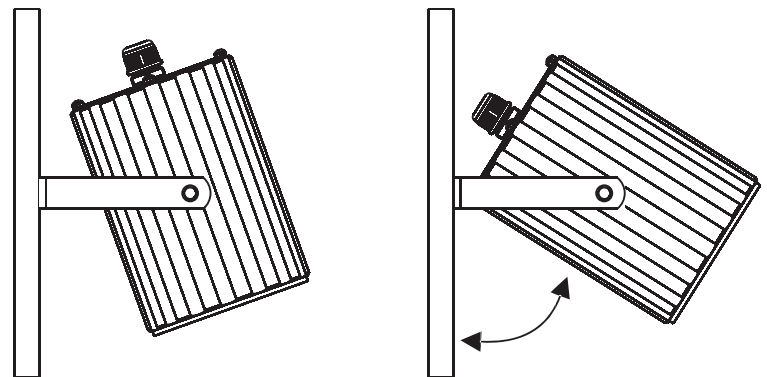

- 6. Re-fit the speaker to the "U" bracket. Position the speaker to the desired angle then tighten the fixings to secure in place.



Penton UK Ltd

Unit 2 Teville Industrials | Dominion Way | Worthing | West Sussex | BN14 8NW
 T: +44 (0)1903 215315 | F: +44(0)1903 215415 | E: sales@pentonuk.co.uk

www.pentonuk.co.uk

OCTOBER 2012



RoHS

